

BONE CRUSHER®

900

**BATCH FEED
FOOD WASTE DISPOSER
3/4 HORSEPOWER**

The Bone Crusher Batch Feed disposer utilizes a stopper/actuator which makes operation safer and quieter and eliminates the need for an outside on/off switch.

It also features a 3-Bolt Mount System for fast replacement of existing 3-Bolt installations.

Corrosion Proof

Bone Crusher 900 Batch Feed model carries a lifetime warranty against failure due to corrosion.

Permanent Magnet Motors

Bone Crusher motors offer maximum torque instantly with the power to cut through potential jams.

Attached Power Cord

Ready to plug in.

HORSEPOWER	3/4 HP
MOTOR SPEED RPM	2700 RPM
VOLTAGE	120v
AMPS	6
CYCLES	60
BEARINGS	Permanently Lubricated, Sleeve Type
MOTOR TYPE	Permanent Magnet
GRIND RING	Stainless Steel
SWIVEL IMPELLERS	Cast Stainless Steel
BALANCED TURNTABLE	Stainless Steel
BALANCED ARMATURE SHAFT	Yes
HOPPER	Corrosion Proof
DRAIN HOUSING	Corrosion Proof
APPLIANCE PROTECTOR	Manual Reset
SINK FLANGE	Stainless Steel
MOUNT ASSEMBLY	3-Bolt
SOUND SHELL	Full
ATTACHED POWER CORD	Yes
DISHWASHER CONNECTION	Yes
UNIT WEIGHT	13.6 lb
INDIVIDUAL SHIPPING WEIGHT	15.4 lb
LIFETIME CORROSION GUARANTEE	Yes
WARRANTY	10 YEARS



BIO SHIELD
(Antimicrobial)
for **ODOR PROTECTION!**
Disposers are treated with an antimicrobial agent molded inside providing protection against odor causing bacteria growth.



The **TORQUE MASTER Grinding System** is a combination of computer designed and balanced components working in unison to provide superior torque grind speed and long system life.

Dimensions

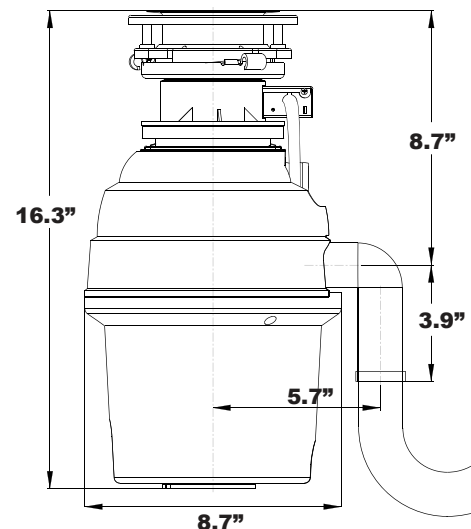

Joneca Company, LLC

4332 E. La Palma Avenue, Anaheim, California 92807
Telephone: 714.993.5997 Fax: 714.993.2126 Toll Free 1-888-8Joneca
Website: www.Joneca.com Email: ContactUs@Joneca.com

©2015 Joneca Company, LLC, All Rights Reserved.

SS-900BF-3B-211